

## TECHNICAL SPECIFICATIONS

### DATA SHEET

Output Voltage	28Vdc
GPU performance	800A continuous/ 1200A for 10 sec. / 2000A for 5 sec.
Output available	N°1 x 28Vdc cable length 10 meters
Engine	Diesel engine, 4 strokes, water cooled
Rated speed	1800 rpm
Configuration	Slow towing trailer
Max towing speed	30Km/h
Fuel tank capacity	185 l.

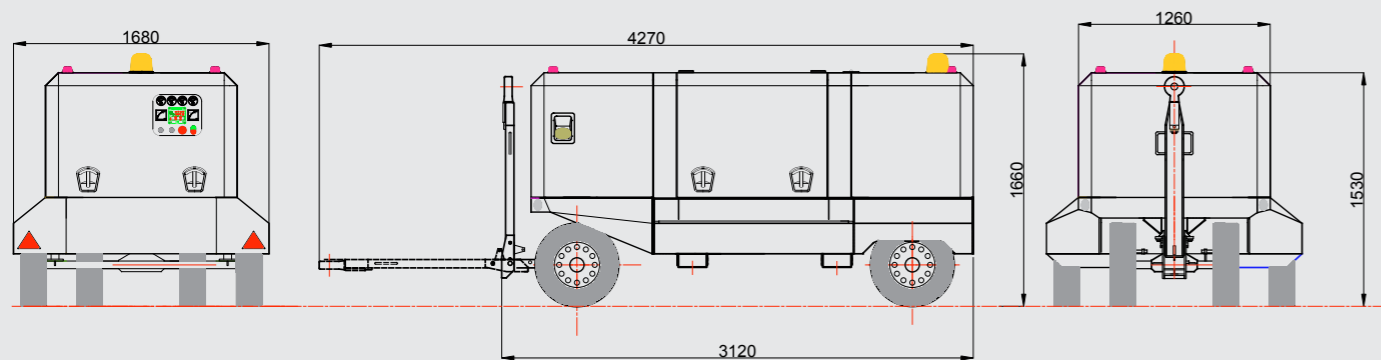

### DIMENSIONS

Length (L)	3120 mm – towbar up
Width (W)	1680 mm
Height (H)	1660 mm (beacon included)
Weight	2000 Kg



## Ground Power Unit **GPU EFFETI - FT99-28**



ricreativ.it

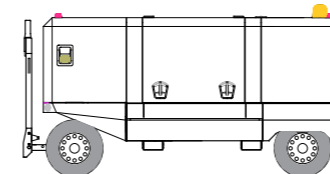

**EFFETI srl**

via Leopardi, 2 - 44042 Cento (FE) - Italy - Ph. +39 051 901616 - Fax +39 051 904437

www.effeti.it - info@effeti.it

AIRPORT TECHNOLOGY





## GPU EFFETI - FT99.28

The unit has been designed focusing on client real needs on ramp and manufactured following EFFETI quality standard, GPU EFFETI series FT28 intended for DC current supply combines sturdiness, safety and reliability with a neat design that suits perfectly to all your needs. Simple and user friendly, thanks to its gull-wing door opening system on three sides, ensures the widest accessibility to all the unit's internal components, granting simple and most importantly fast and comfortable maintenance operations.



### DC Output 1 x 28Vdc

#### ENGINE

- Diesel engine, 4 strokes, water cooled
- Rated speed: 1800 rpm
- Electric system 12V
- Protection against low oil pressure, high water temperature, overspeed
- Oil and fuel filters
- Air dry filter
- Coolant radiator with pushing fan
- Self-excited and self-regulated
- Voltage: 28V
- Automatic voltage regulator

#### PERFORMANCE 28Vdc

- Rectifier Unit 28Vdc/2000A
- 800A continuous
- 1200A for 10 sec
- 2000A for 5 sec

#### OUTPUTS

- N. 1 x 28 Vdc cable length 10 meters

#### REGULATION

- Voltage precision:  $\pm 1\%$  from 0 to full load (transient)
- Voltage regulation:  $\pm 15V$

#### PROTECTION

- Features in accordance with ML-STD-704F (Aircraft Electric Power)

#### ENVIRONMENT

- Working temperature:  $-20^{\circ}C / +45^{\circ}C$
- Rel. Hum.: 10-90%
- Altitude: 1000 meters above sea level

#### SOUNDPROOF CANOPY

- Sheet steel made canopy with soundproof material
- Gull-wing door opening to grant the maximum accessibility for maintenance of the main components
- N. 6 lockable handles for doors opening/closing
- Noise Level 72 Db at 7 Meters

#### TRAILER

- Trailer for on-ramp use max speed 30 Km/h complete with:
  - N.4 pneumatic wheels with rear spring leaf mounted on axle
  - Steering front axle and fixed rear axle
  - Foldable towbar complete with towing eye
  - Parking brake on the towbar with automatic insertion and disconnection
  - Rear and front size lights
  - N.2 side trays for cable allocating complete with easy-deploy roll system for an easier extraction

- ✓ RATED AT 1800 r.p.m.
- ✓ ENVIRONMENT FRIENDLY
- ✓ OPTIONS AVAILABLE
- ✓ EFFECTIVE AFTER SALES SERVICE

#### CONTROL BOARD

- On/Off selector DC circuit
- Engine start button
- Emergency stop button
- 28 Vdc output on/off buttons
- Voltmeter
- Ammeter
- Hour meter
- Fuel level indicator
- Engine water thermometer
- Oil pressure manometer
- Electronic device for GPU command and control, mod. EFFETI PIC 0192, equipped with led indicators for the following alarms:
  - Low oil pressure
  - High engine temperature
  - Low fuel level
  - Over speed
  - Over load ( max current )
  - Belt failure
  - Over/Under voltage 28 V
  - High diodes temperature

#### FINISHING

- Standard color White RAL 9010
- Other color finishing upon request

#### OTHER FEATURES

- Exhaust muffler is allocated inside the canopy protected from bumps and accidental contacts complete with internal spark arrester
- N. 1 fire extinguisher homologated, capacity 6 Kg
- N.1 Service beacon light
- N.4 LED size lights



Quality management system: ISO 9001:2008

#### ACCESSORIES AVAILABLE

- Electric starting 24 V
- Other color finishing upon request
- Protection for DC plug
- Handle for DC plug
- Engine pre-heating system

